

MT12SM-LL Pre-Angled Ferrule

Features

- Manufacture cost and time can be reduced by Pre-angled structure.
- Fully made in Japan (Material, Molding die and MT ferrule).
- MT boot is selectable from 2 types (Normal / Tight).

Characteristic

Item	Value
Max. IL vs. Master	<0.35 dB

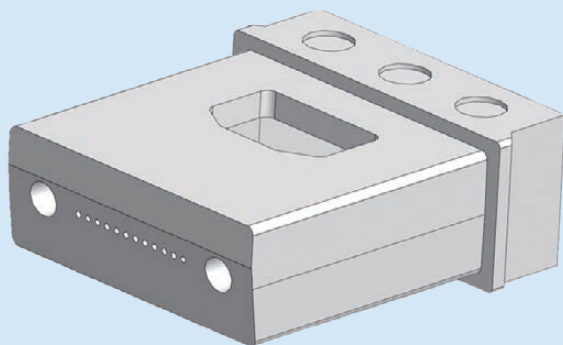

Insertion loss @1310nm
for MT12SM-Low Loss Pre-angled

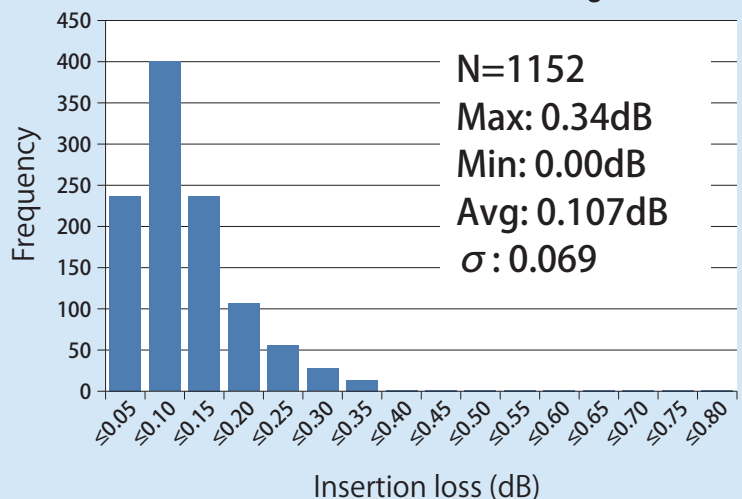

*Above optical performance is confirmed by Furukawa Electric fiber, cable, master, polishing process, and testing method.

*This document is for informational purposes only and is not intended to modify or supplement any warranties or specifications relating to any of its products or services.

FURUKAWA ELECTRIC CO., LTD.

Head Office

Marunouchi Nakadori Bldg., 2-3, Marunouchi 2-chome, Chiyoda-ku, Tokyo 100-8322, Japan

TEL: +81-3-3286-3452

<https://www.furukawa.co.jp/connector/index.htm>



Export Control Regulations

The products and/or technical information presented in this publication may be subject to the application of the Foreign Exchange and Foreign Trade Act and other related laws and regulations in Japan. In addition, the Export Administration Regulations (EAR) of the United States may be applicable. In cases where exporting or reexporting the products and/or technical information presented in this publication, customers are requested to follow the necessary procedures at their own responsibility and cost. Please contact the Ministry of Economy, Trade and Industry of Japan or the Department of Commerce of the United States for details about procedures.